

# Burns Engineering, Inc.

RTD or Thermocouple  
What's the right choice?

Bill Bergquist, Sr. Applications Engineer

---

---

# Agenda

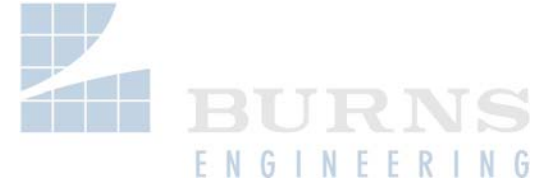

- Thermocouple
    - Basic Operation
    - Types
    - Temperature Range
    - Performance
  - RTD
    - Basic Operation
    - Types
    - Temperature Range
    - Performance
  - Sensor selection
  - Typical applications
  - Questions
-

# Thermocouple

## ■ Basic Operation

- ❑ Made by connecting two dissimilar metals to create a small voltage (5 to 6 mV @ 100°C)
- ❑ Voltage changes with change in temperature
- ❑ Require cold junction compensation – typically handled by the measurement electronics



# Thermocouple

## ■ Types

- Junctions can be grounded, ungrounded or exposed

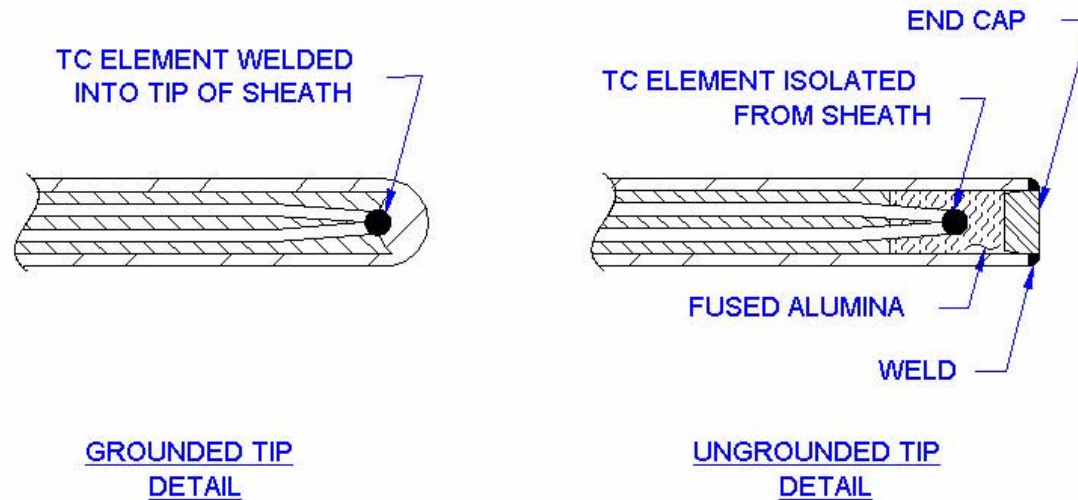

# Thermocouple

- Types

- Most common

- Type T: Copper-Constantan Red/Blue
    - Type J: Iron-Constantan Red/White
    - Type E: Chromel-Constantan Red/Purple
    - Type K: Chromel-Alumel Red/Yellow



- Less common

- R, S, B Platinum/Platinum-Rhodium 2640°F
    - W3, W5 Tungsten/Tungsten-Rhenium 4200°F

- Each type has a different temperature range and Voltage vs. Temperature relationship

# Thermocouple

## Temperature range

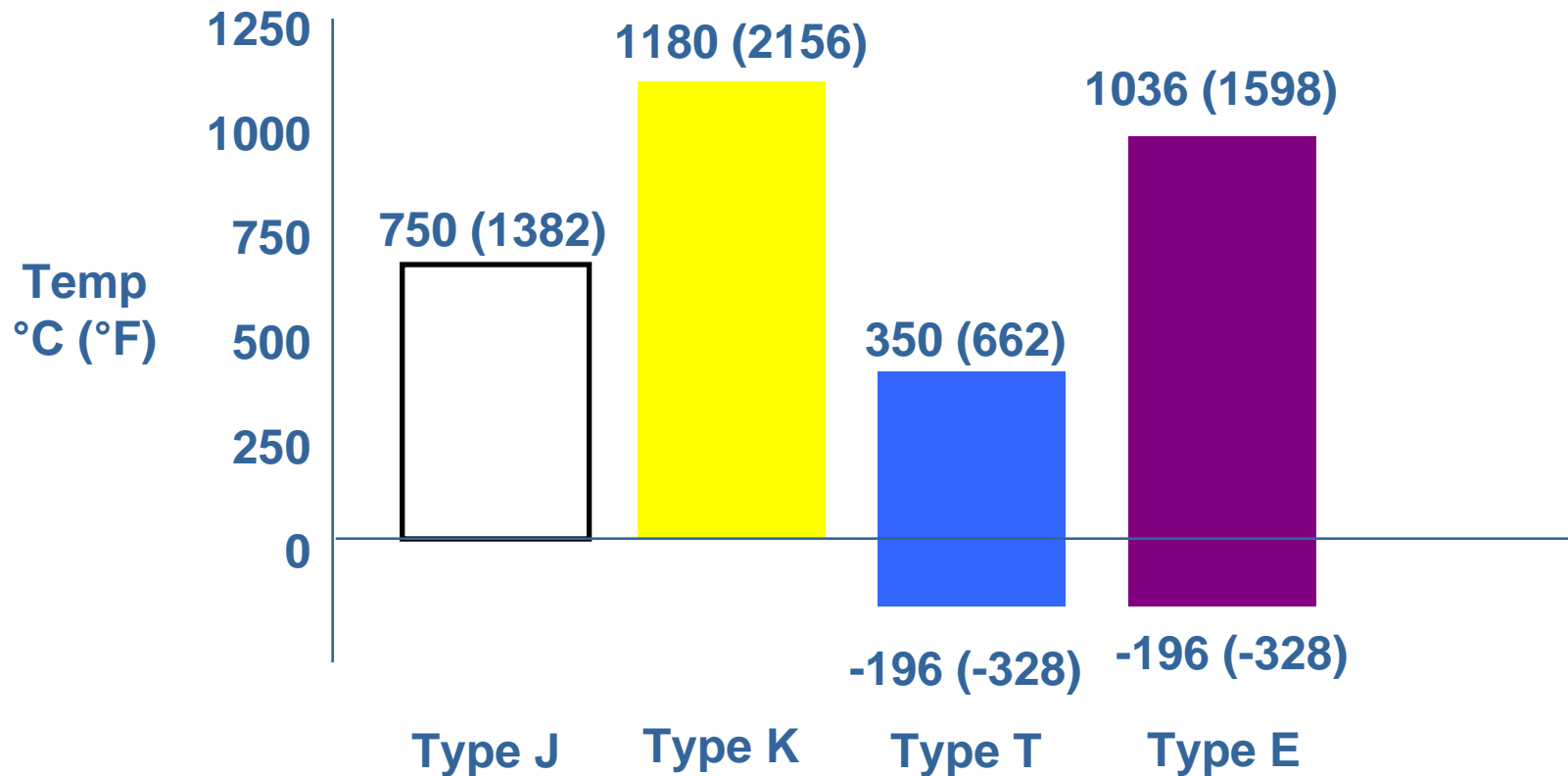

---

# Thermocouple



- Performance

- Specifications

- Built to ASTM E-230 special or standard limits of error
      - Sheath material is 316 SST on type T, J, E and Inconel 600 on type K to handle the higher temperatures
      - Larger wire required for higher temperatures
      - Lead wires are mineral insulated and color coded per ASTM E-230
-

# Thermocouple

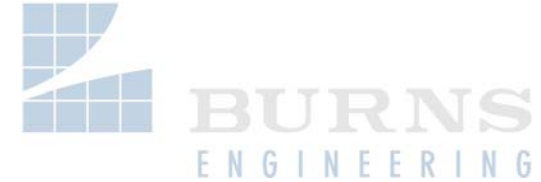

## ■ Performance

- Accuracy - standard or special limits of error wire as defined by ANSI MC 96.1

<b>Temperature Range &amp; Initial Calibration Tolerances</b>			
<b>Thermocouple Type</b>	<b>Temperature Range</b>	<b>*Standard Limits greater of</b>	<b>*Special Limits greater of</b>
T	-200°C to 350°C	± 1.0°C or ± 0.75%	± 0.5°C or ± 0.4% **
J	0°C to 750°C	± 2.2°C or ± 0.75%	± 1.1°C or ± 0.4%
E	-200°C to 870°C	± 1.7°C or ± 0.5%	± 0.5°C or ± 0.4% **
K	0°C to 1180°C	± 2.2°C or ± 0.75%	± 1.1°C or ± 0.4%
* % applies to temperature measured in °C			
** -200°C to -170°C error is 0.8%			

---

# RTD

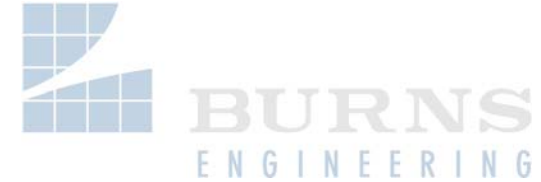

## ■ Basic Operation

- ❑ RTD = Resistance Temperature Detector or PRT (Platinum Resistance Thermometer)
  - ❑ Resistor made from platinum, nickel, or copper
  - ❑ Most common material is platinum due to purity and consistency/predictability (linear R vs. T)
-

---

# RTD



## ■ Basic Operation

- ❑ How it works – Small current is sent through the resistor element and electrical resistance is measured
  - ❑ Resistance changes very predictably with temperature changes
  - ❑ Performance defined by IEC 60751 and ASTM E1137
-

# RTD

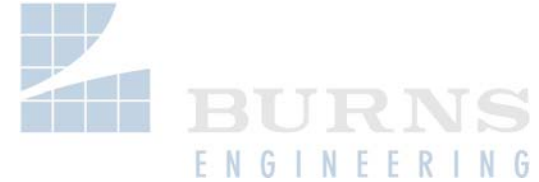

- Basic Operation

- Temperature coefficient

- Also called the Temperature Coefficient of Resistance or alpha
    - Units are ohms/ohm/°C
    - The average change in resistance per unit change in temperature between 0 and 100°C
    - $\alpha = R_{100} - R_0 / 100^{\circ}\text{C} * R_0$ 
      - $R_0$  = resistance at 0C
      - $R_{100}$  = resistance at 100C

---

# RTD

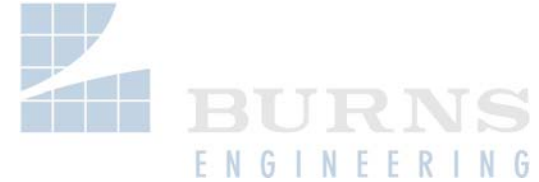

## Most common coefficients

- 0.00385 – DIN 43760 or IEC 60751
  - 0.003902 - American
  - 0.003916 – Japanese
  - 0.003925 - SPRT, Secondary SPRT
  - Must match your instrument to the proper temperature coefficient of your sensor
-

- Coefficient example

- A temperature is being measured with a sensor having a temperature coefficient of .003916 (JIS) but due to a sensor failure it was replaced with a sensor having a temperature coefficient of .00385.
  - If the transmitter/controller is not recalibrated, at 100°C it will read 1.7°C low.
-

# RTD

## ■ Types

- Elements
  - Wire wound
    - External wound
    - Coil
  - Thin Film
- Single or Dual

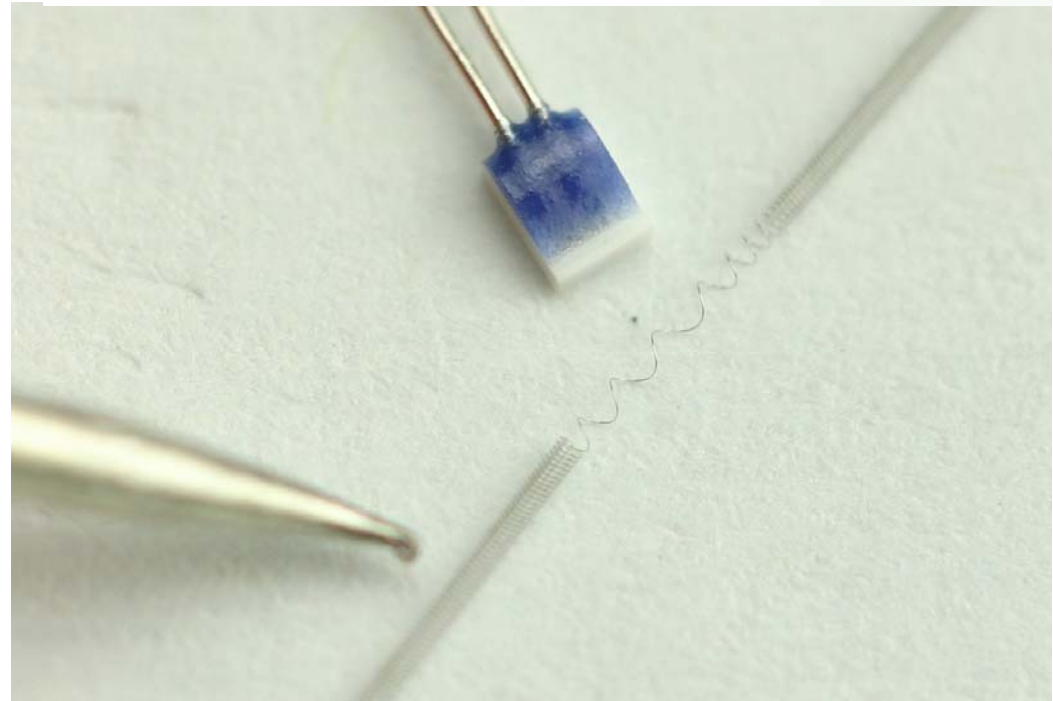
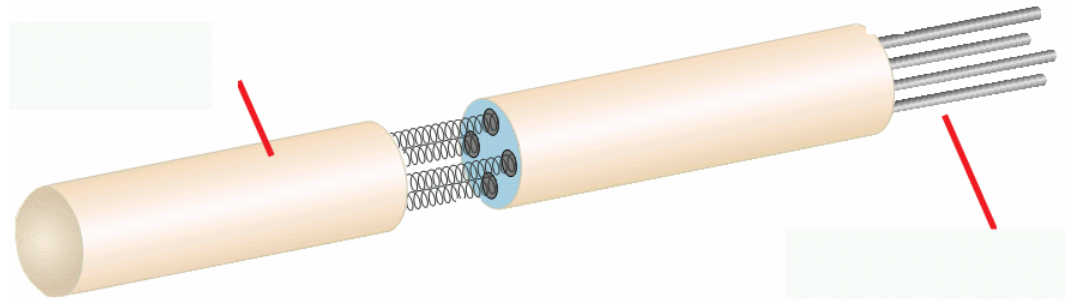

# RTD

- Wires
  - 2, 3, and 4 Wire

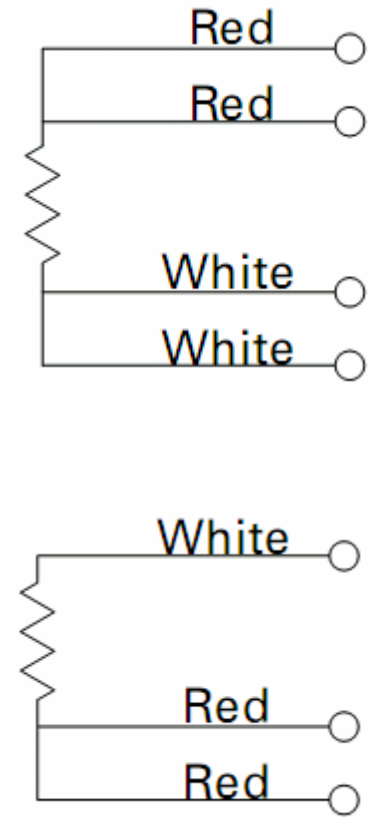
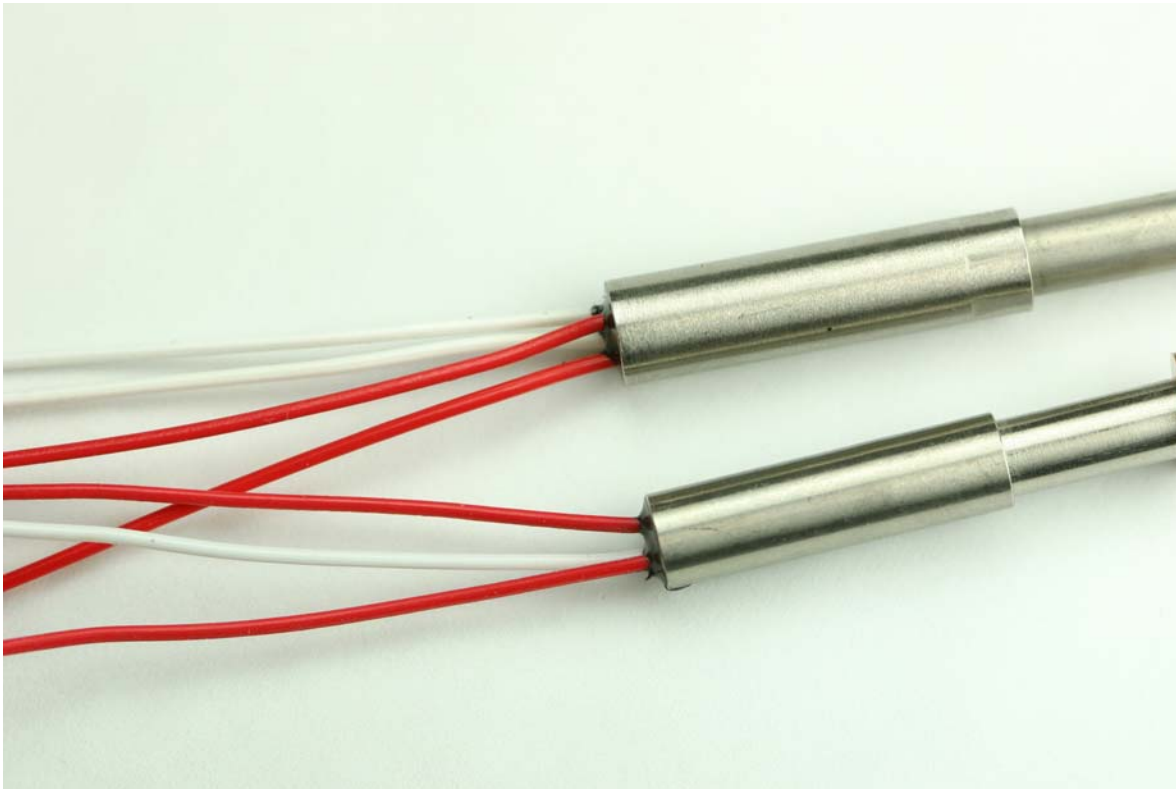

# RTD

## Temperature range

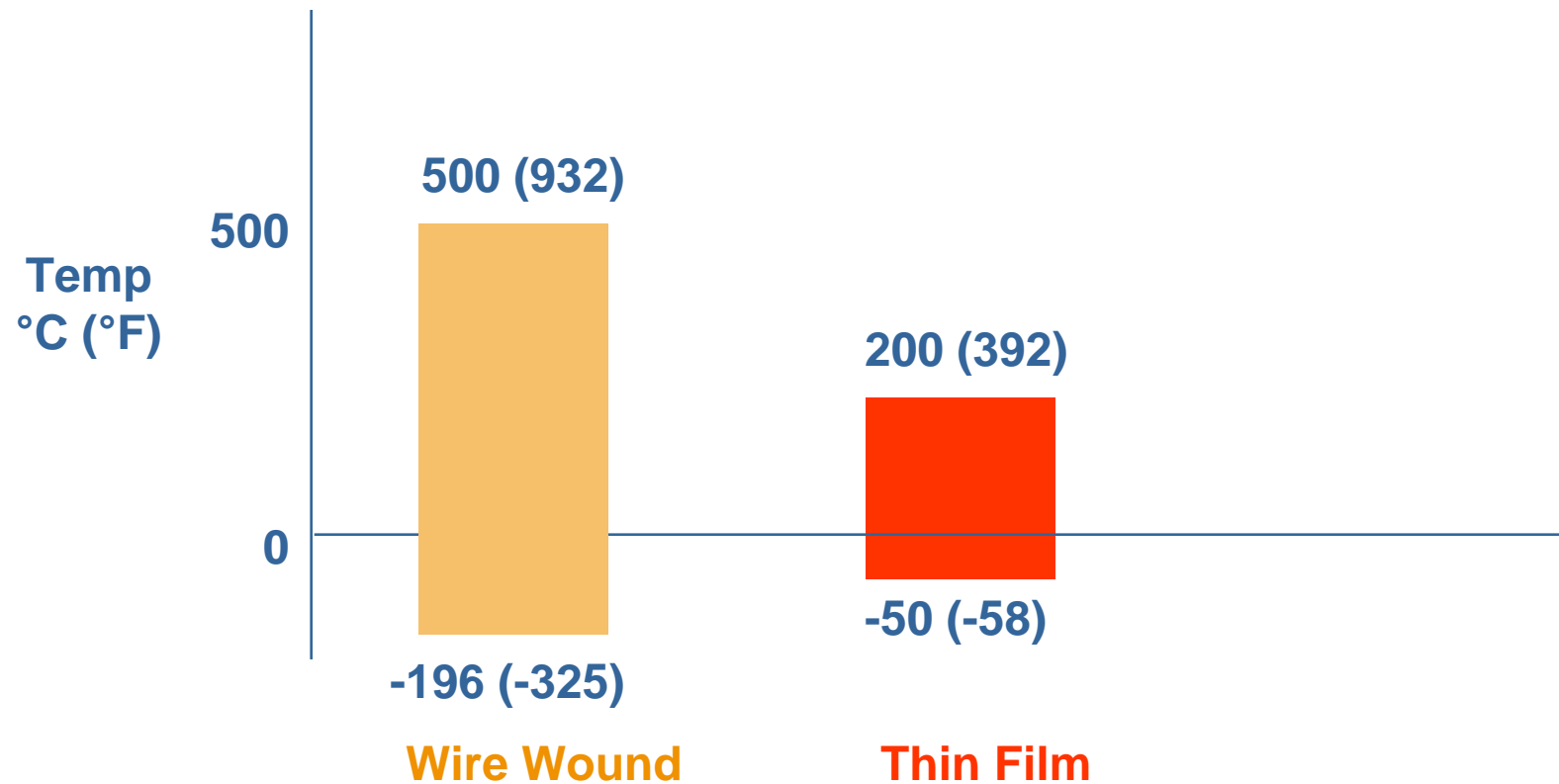

# RTD

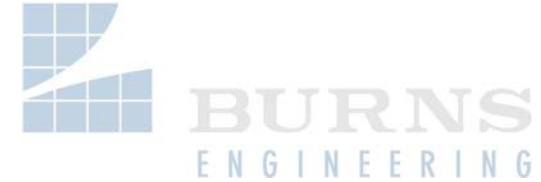

## ■ Performance

	<b>Wire Wound</b>	<b>Thin Film</b>
Element Resistance	100 ohms	100, 1000 ohms
Accuracy 0°C/200°C	± 0.13°C/0.5°C	± 0.26°C/1.0°C
Repeatability	0.1°C	0.1°C
Time Response	4.0 Sec.	6.0 Sec.
Temp. Range	-200 to 500°C	-50 to 200°C
Vibration	15 g's	20 g's
Stability	.1°C	.5°C

---

# Sensor Selection

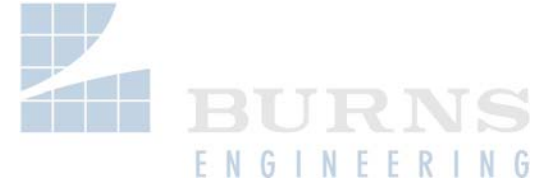

- RTD or Thermocouple?
    - ❑ Performance
    - ❑ Process characteristics/needs
    - ❑ Environment
    - ❑ Cost considerations
-

# Terminology Refresher: Accuracy / Repeatability

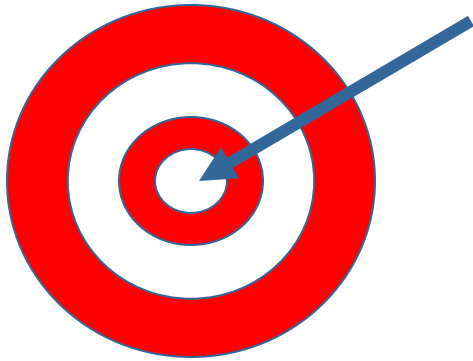

**LUCKY**

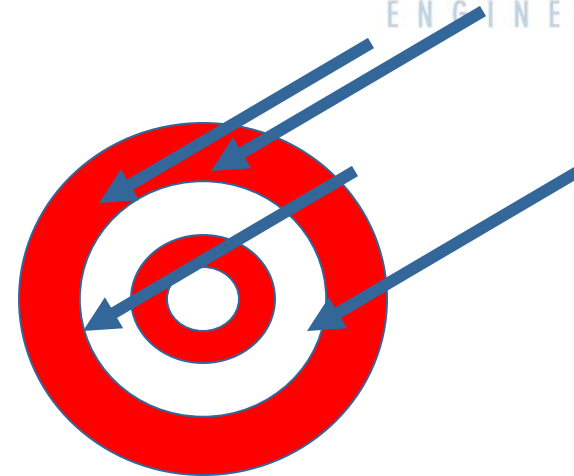

**UNREPEATABLE**



**REPEATABLE**

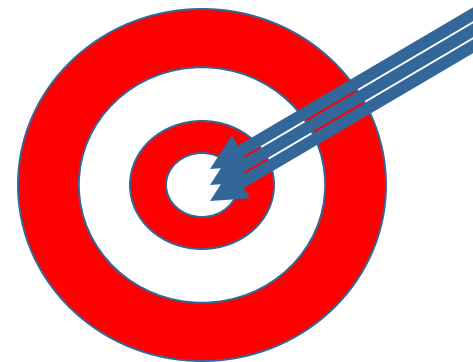

**ACCURATE &  
REPEATABLE**

# Selection

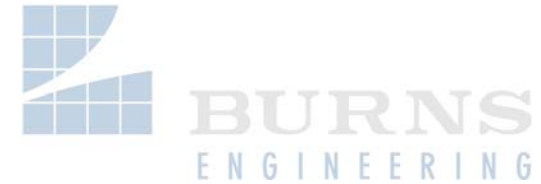

## ■ Performance

Consideration	Thermocouple	RTD
Accuracy at 32°F	Standard limits: $\pm 4^\circ\text{F}$ Special limits: $\pm 2^\circ\text{F}$	Standard: $\pm 0.46^\circ\text{F}$ Precision: $\pm 0.23^\circ\text{F}$
Calibration	Limited to in-place calibration	- Easily recalibrated for longer service life and traceability - Matching transmitter improves performance
Stability	Dependent on wire homogeneity and process conditions	$\pm 0.13^\circ\text{C}$ after 1000 hours at $400^\circ\text{C}$
Repeatability	Highly dependent on process characteristics	Less than $\pm 0.04\%$ change in ice point resistance after 10 cycles $-200$ to $500^\circ\text{C}$ .

# Selection

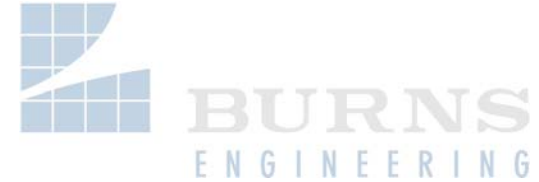

## ■ Process characteristics

Consideration	Thermocouple	RTD
Temperature range	-200°C to 1180°C	-200°C to 500°C
Time response	Bare wire: less than 1 millisecond Typical packaging: 2 to 3 seconds	2.5 seconds Typical packaging 4 to 6 seconds
Size constraints	Can be less than 1/8" in diameter	Smallest diameter 1/8", typically 3/16" or 1/4"

# Selection

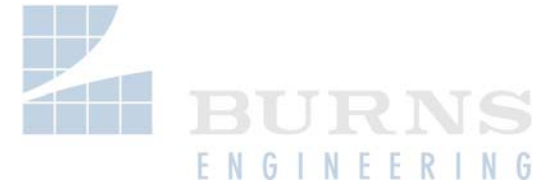

## ■ Environment

Consideration	Thermocouple	RTD
Vibration	Best choice for extreme conditions – shock or vibration	Limited to 30 g's at 5 to 350 Hz
Ambient temperature	Either	Either
Control system	Either	Either
Distance to control system	Local transmitter often less expensive than lead wire – robust signal	Add a local transmitter if over 300 ft.

# Selection

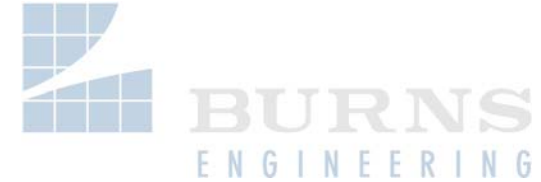

## ■ Cost considerations

Consideration	Thermocouple	RTD
Initial cost	Low	Medium to high
Installation influences	<ul style="list-style-type: none"><li>- Lead wire is expensive</li><li>- RFI/EMI considerations</li></ul>	<ul style="list-style-type: none"><li>-Uses standard 18 AWG instrument wire</li><li>-Less RFI/EMI interference</li></ul>
Energy costs	Less accuracy means less control over energy usage	Accurate control of energy consumption = \$\$ savings
Replacement	Low cost but more frequent replacement is necessary	<ul style="list-style-type: none"><li>- Can last many years</li><li>- Lowest life cycle cost</li></ul>

# Typical Applications

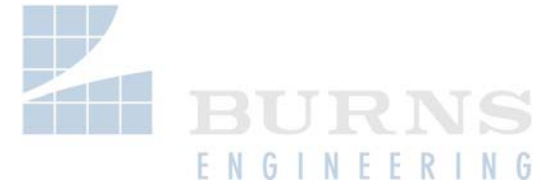

- Thermocouple
  - Exhaust gas
  - Injection molding
  - Bearings
  - Refinery
- RTD
  - Pharmaceuticals
  - Fuel custody transfer
  - Chemical
  - Tire /rubber



# Quick guide

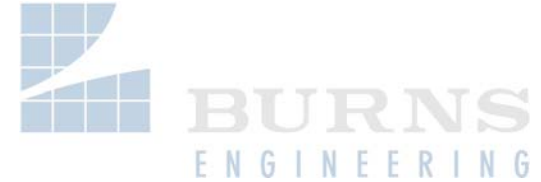

Situation	Thermocouple	Wire Wound RTD	Thin Film RTD
Accuracy/Stability		X	
Low Temp (-50 to 200°C)		X	X
High Temp (-200 to 500°C)		X	
Higher Temp (up to 1260°C)	X		
Time Response (< 6 sec.)	X	X	
Long-term Stability		X	
High Vibration (g level)	X		X
Extra High Vibration, Shock	X		X
Critical Temp. Application		X	

---

# Summary

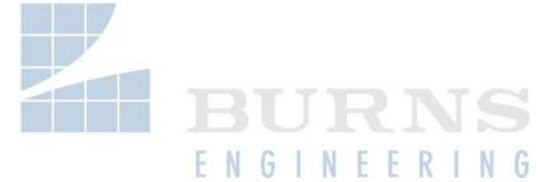

- Every application is different
- Start with an RTD, if process conditions exclude usage then look at a thermocouple



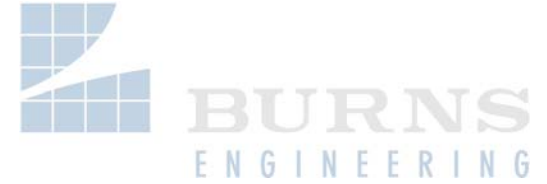

# Questions?

Use the chat window to send us a question now

Contact us later at 800-328-3871 ext 13 or 11  
or visit [www.burnsengineering.com](http://www.burnsengineering.com)

---

# Thank you for attending!

## Watch for upcoming RTDology™ events

- ❑ Accuracy improvement techniques
- ❑ Calibration
- ❑ Sensor selection and applications

**Burns Engineering, Inc.**  
Temperature Measurement Experts

---