

Time Response Testing of Surface Sensors

Time Response Testing of Surface Sensors

Introduction:

Surface temperature sensors are designed for applications where it is not suitable or feasible to monitor temperature using an immersion sensor, but where monitoring temperature is still important. Certain surface sensor designs do not meet the requirements of the alternative method for testing thermal time response of surface sensors in ASTM E644. Therefore, a different method for testing thermal time response of surface sensors is necessary. The following test method defines the apparatus and methods used at Burns Engineering to provide a comparison across a range of surface sensor designs. The discussion section offers a practical guide and elaborates on the installation and design attributes which may influence thermal response time in the field.

Terminology:

Thermal response time¹- the time required for a thermometer to respond to a step change in temperature. See Figure 1.

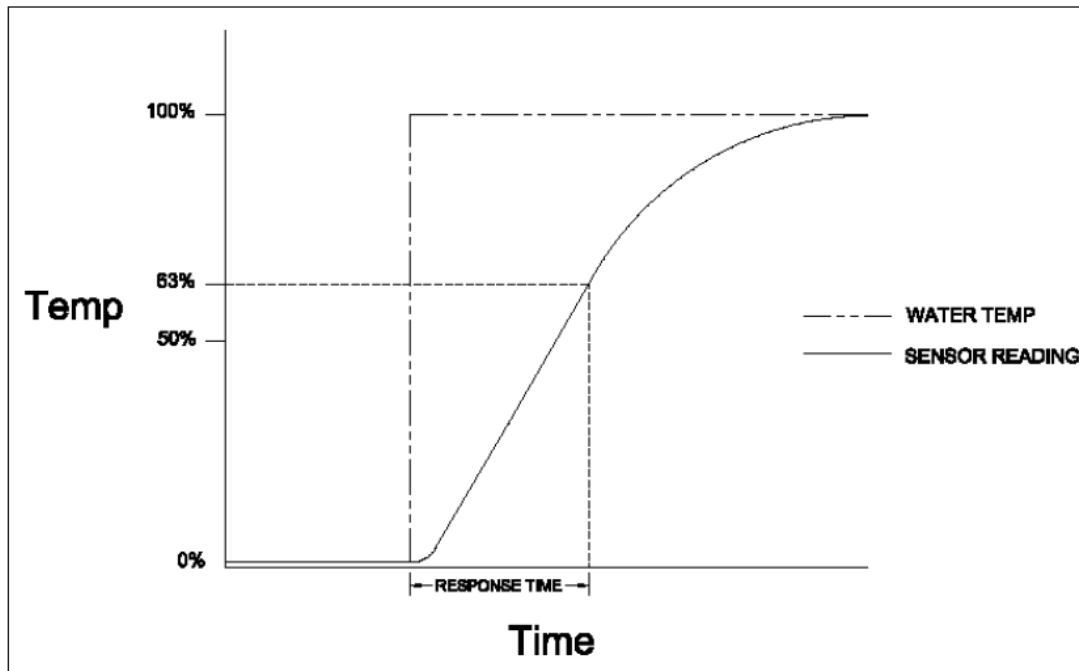

Figure 1: Thermal time response to a step change in temperature

¹ Standard definition as described in ASTM E644-08

Apparatus:

The testing apparatus consists of two reservoirs, filled with hot and cold water respectively. The temperature difference between the two reservoirs is approximately 45°C. Two directional control valves are utilized to control whether hot or cold water is moving through the system. The sensor is mounted on a standard 2" OD x 0.065" wall stainless steel test pipe. A pump with a flow control valve ensures the water is pumped through the system at 3 fps. See Figure 2.

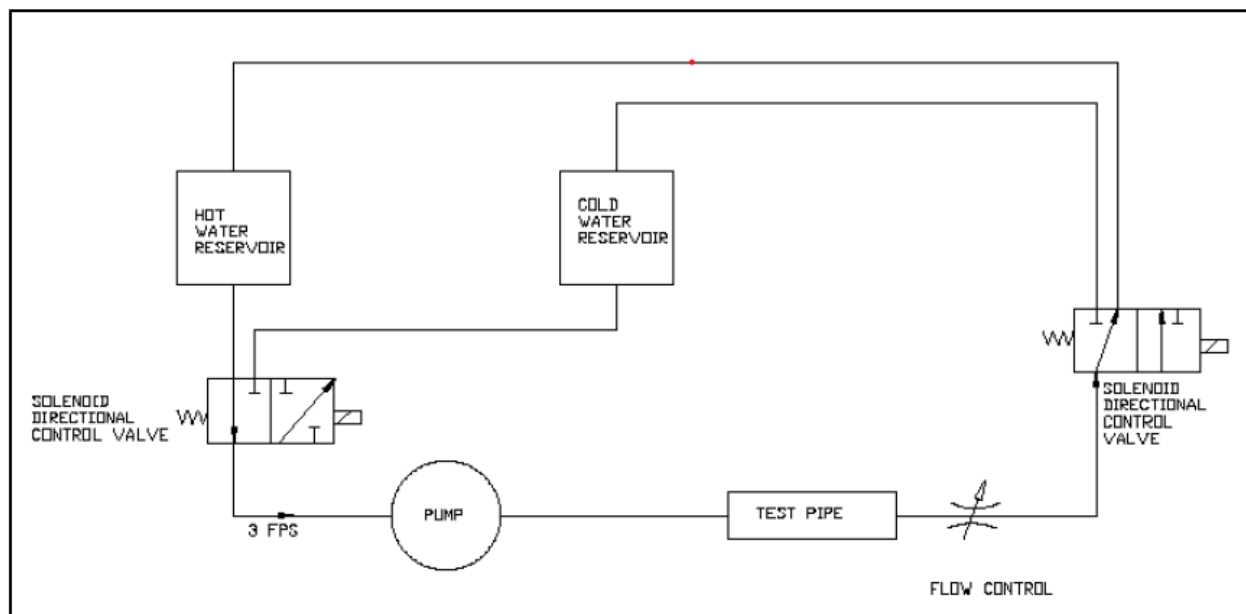

Figure 2: Schematic of time response test apparatus

Attached to the sensor under test is a meter/resistance measurement instrument that is capable of measuring the sensor resistance, such as a Multimeter. A recorder that records resistance values and associated time intervals is connected to the measurement instrument.

Procedure:

Mount the sensor to the test pipe so that its sensing surface is in solid contact with the test pipe. Wrap entire length of test pipe, including sensor, with 1" thick fiberglass insulation, allowing access for the sensor lead wires to be attached to the meter / recording instruments.

Pump water from cold water reservoir through the pipe system. Allow the temperature sensor to stabilize at the low temperature. Switch direction to pump from the hot water reservoir on both directional control valves simultaneously. When the hot water begins flowing, record the resistance of the sensing element over time, and continue until the sensor has stabilized. Take at least three sets of test data for each sensor design.

Discussion:

The thermal response time established by this test method corresponds to a specific heat transfer condition. Certain variables in sensor design, mounting conditions, pipe or tube wall thickness, and measurement systems will yield different results. Care should be taken if a correlation from this test method to the actual installation is being considered. Actual thermal conditions are likely to be different, therefore, interpreting the results from Burns' test lab as representative of the install performance is not recommended. The method is intended to provide a general basis of comparison for the response times of different surface sensor designs. Response time values stated by Burns Engineering represent the time to 63.2% of the step change in temperature with a 95% confidence level (Test data average value plus 2 standard deviations of the test data for each sensor design).

Certain characteristics can significantly affect thermal response time in any measurement system.

- Matching the geometry of the mounting area, whether flat or curved, to the geometry of the sensor surface will maximize surface contact and heat transfer to the sensing element, thereby yielding a faster time response.
- Thermal grease between the sensor surface and the measurement surface will provide a more consistent path of conductivity between the measurement surface and the sensor surface and may result in a faster time response.

- The placement of the sensing element or thermocouple within the sensor package will affect the thermal time response. If the mounting orientation of the sensor is critical, a reputable manufacturer will identify which surface of the sensor is the contact surface. Not mounting the sensor per this guidance will significantly increase the response time and could have a detrimental effect on measurement accuracy.
- A more conductive sensor package may considerably decrease time response. Highly conductive metals, such as aluminum, conduct heat faster than steel. Similarly, the heat transfer characteristics of the mounting surface may influence thermal time response significantly, depending on the material to which the sensor is mounted.
- The mass of the temperature sensor will affect time response. A more massive sensor will decrease the thermal response time. Likewise, the mass of the process system itself will affect time response. Therefore, it is most appropriate to evaluate the relative mass of the sensor in relation to the process system in which it is installed.

Conclusion:

It is important to realize that time response of a surface sensor is directly dependent on the sensor design, application, and process system. Surface sensor designs may favor space requirements, durability, or mounting approaches that are unique to this type of sensor. Nonetheless, thermal time response may be an important attribute when choosing a surface temperature sensor. A relative thermal response measure of sensor designs through a consistent test method, along with knowledge of the external variables which may affect time response will ensure a well-matched surface sensor for the application and temperature of interest.